

INDUSTRIAL PC 211



Features

- 15" TFT LCD (LED Backlight) with PCAP Touch
- Built in i3 (Intel Core i3 6100-U)
- Clear Cable Management
- Low power & fanless operation without heat ventilation holes
- Easy access to key components
- Easy peripheral mount design integrated
- Device Options: 2nd Display, MSR, VFD, RFID, Barcode Scanner



Introduction:

The IPC 211 is a next-generation panel PC featuring a 15" Fanless Panel PC with Intel Core i3-6100U Processor with 1024 x 768 resolution.. Powered by a high-performance processor, the system's high-efficiency fanless thermal design allows heat to dissipate rapidly. By combining high performance with reliability, IPC 211 provides a superior human-machine interface. Our IPC 211 has shock resistance of 10G peak acceleration. Also, IPC 211 has vibration of 5~500Hz 0,5 Grms. Finally, IPC 211 has 10-point multi-touch feature which ensures convenient and intuitive operation for the optimal user experience.

Highlights



Foldable design with dual hinge



Toughened Soda lime Glass



Wall Mount, via VESA mount kit



□ 1xUSB port on backside w/ rubber cover for USB port to ensure data security (Optional) Screwed bracket design

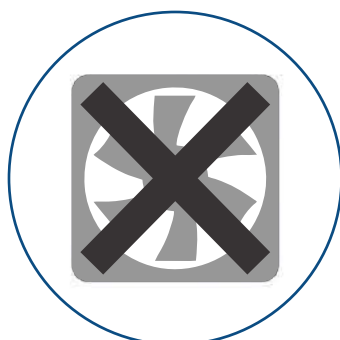

Fanless design

• Feature Points •

- ☑ IP 65 sealed front panel with touch design
- ☑ Soda lime glass with 7H hardness
- ☑ table top/wall mount stand/kit (which is aluminium body) acts as Heat sink
- ☑ Bezel free & PCAP Touch Screen
- ☑ True Vent free machine

Toll Free Number
1800 212 4520

For Support & Service

INDUSTRIAL PC 211

Specifications

Model	Industrial PC 211
Processor	CORE, i3-6100U
Memory	Up to 16GB DDR3L-2133
Storage	1 x 2.5" SA TA HDD/SSD connector, SATA3 (6.0Gb/S)
Panel	15" TFT LCD Display (1024 x 768), 250 cd/m ²
Touch Screen	Projected Capacitive Touch Panel (PCAP. Flat Glass) Light Transmission: Res. Touch 80% +/-5% / Pcap Touch 85%+/-3%
Bus Expansion	1 x Mini PCIe (for Wi for 3G), shared with mini SATA connector
Audio	1 x 2W speaker installed. 1 x Line out & 1 x Mic in (Optional)
Power Supply	60W power adapter
Serial Port	2 x COM RS232 ports on I/O board via RJ-48 connector, COM1 / COM2 support 5V & 12V by order Internal: 4 x COM port, COM3 for 5W Res. touch, COM4, COM5 support 5V & 12V by order, COM6 no power
USB Port	External: 2 x USB3.0, 1 x USB2.0; Internal: 3 x USB2.0 (1 x USB for PCAP touch)
Ethernet	LAN controller: Intel WGI219LM, 1x RJ-45 Gigabit Ethernet
Display Output	1 x VGA, 1 x DP
PS2	1 x PS2 (optional)
Parallel Port	1 x LPT (optional)
IP65	IP65 front panel protection
Dimension (W x H)	354(W) x 327(H) x 237(D)mm, Stand: 237 x 200 mm
Weight	5.2KG (Net weight) / 6.9KG (Gross weight)
EMC / Safety	CE, CCC, UL, FCC, CB/LVD, VCCI, BSMI
Operating Temp.	0 ~ 40° C
Relative Humidity	10 ~ 90% @ 40° C
Shock	10G peak acceleration (11ms duration)
Vibration	5~500Hz 0.5Grms, random
OS Support	POSReady 7, Windows 7 Pro, Windows 8.1 Pro (64-bit) Windows 10 IoT Enterprise, Linux Kernel 3.13 or above

Dimensions

Unit: mm

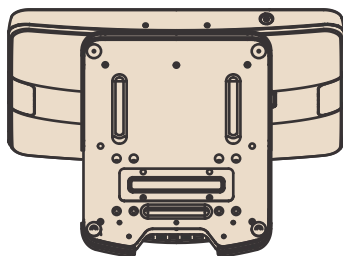
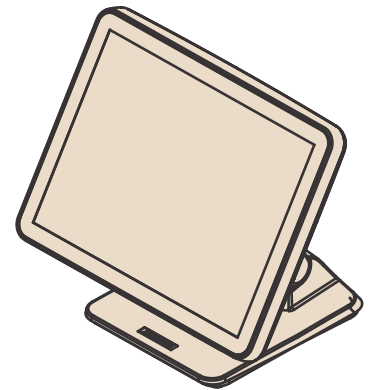
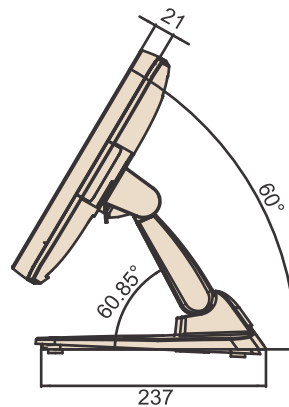
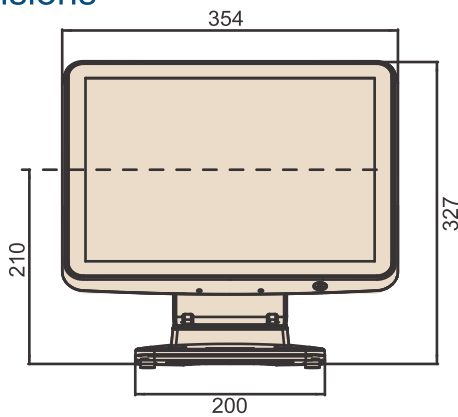

Interface Option

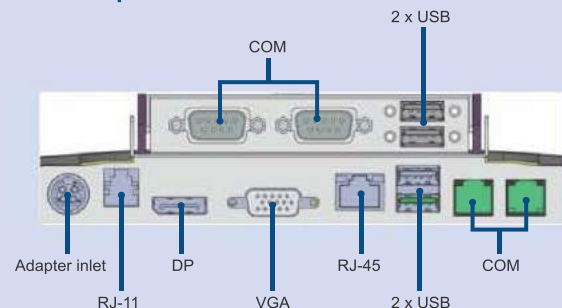

ADVANTECH-RAISER INDIA PRIVATE LIMITED,

H/O: #2nd floor -A-wing, Citi Centre survey No.79/2 Hennur Bellary Outer Ring Road,
Hebbal Village, Kasaba Hobli, Bangalore North Taluk, Bangalore-560024.

C/O: Unit No. 8, 1st Floor, Balwa Techniplex II, Off SV Rd, Goregaon West - 400062, Mumbai, India.

Contact Us: 9223434155