

INDUSTRIAL PC 211



Features

- 15" TFT LCD (LED Backlight) with PCAP Touch
- Built in J1900
- Clear Cable Management
- Low power & fanless operation without heat ventilation holes
- Easy access to key components
- Easy peripheral mount design integrated
- Device Options: 2nd Display, MSR, VFD, RFID, Barcode Scanner



Introduction:

The IPC 211 is a next-generation panel PC featuring a 15" Fanless Panel PC with Built in J1900 Processor with 1024 x 768 resolution.. Powered by a high-performance processor, the system's high-efficiency fanless thermal design allows heat to dissipate rapidly. By combining high performance with reliability, IPC 211 provides a superior human-machine interface. Our IPC 211 has shock resistance of 10G peak acceleration. Also, IPC 211 has vibration of 5~500Hz 0,5 Grms. Finally, IPC 211 has 10-point multi-touch feature which ensures convenient and intuitive operation for the optimal user experience.

Highlights



Foldable design with dual hinge



Toughened Soda lime Glass



Wall Mount, via VESA mount kit



Easy Access USB port
 1xUSB port on backside w/ rubber cover for USB port to ensure data security (Optional)
 Screwed bracket design



Fanless design

• Feature Points •

- IP 65 sealed front panel with touch design
- Soda lime glass with 7H hardness
- table top/wall mount stand/kit (which is aluminium body) acts as Heat sink
- Bezel free & PCAP Touch Screen
- True Vent free machine

Toll Free Number
1800 212 4520

For Support & Service

INDUSTRIAL PC 211

Specifications

Model	Industrial PC 211
Processor	Intel Bay Trail Quad Core J1900. 2GHz up to 2.42Ghz
Memory	Up to 8GB DDR3L-2133
Storage	1 x 2.5" SA TA HDD/SSD connector, SATA3 (6.0Gb/S)
Panel	15" TFT LCD Display (1024 x 768), 250 cd/m ²
Touch Screen	15", Analog Resistive 5-wires (Res. Flat Glass) / Projected Capacitive Touch Panel (PCP. Flat Glass) Light Transmission: Res. Touch 80% +/-5% / Pcap Touch 85%+/-3% Touch 85%+/-3%
Bus Expansion	1 x Mini PCIe (for Wi fi or 3G), shared with mini SATA connector
Audio	1 x 2W speaker installed. 1 x Line out & 1 x Mic in (Optional)
Power Supply	60W power adapter
Serial Port	2 x COM RS232 ports on I/O board via RJ-48 connector, COM1 / COM2 support 5V & 12V by order Internal: 4 x COM port, COM3 for 5W Res. touch, COM4, COM5 support 5V & 12V by order, COM6 no power
USB Port	External: 2 x USB3.0, 1 x USB2.0; Internal: 3 x USB2.0 (1 x USB for PCAP touch)
Ethernet	LAN controller: Intel WGI219LM, 1x RJ-45 Gigabit Ethernet
Display Output	1 x VGA, 1 x DP
PS2	1 x PS2 (optional)
Parallel Port	1 x LPT (optional)
IP65	IP65 front panel protection
Dimension (W x H)	354(W) x 327(H) x 237(D)mm, Stand: 237 x 200 mm
Weight	5.2KG (Net weight) / 6.9KG (Gross weight)
EMC / Safety	CE, CCC, UL, FCC, CB/LVD, VCCI, BSMI
Operating Temp.	0 ~ 40° C
Relative Humidity	10 ~ 90% @ 40° C
Shock	10G peak acceleration (11ms duration)
Vibration	5~500Hz 0.5Grms, random
OS Support	POSReady 7, Windows 7 Pro, Windows 8.1 Pro (64-bit) Windows 10 IoT Enterprise, Linux Kernel 3.13 or above

Dimensions

Unit: mm

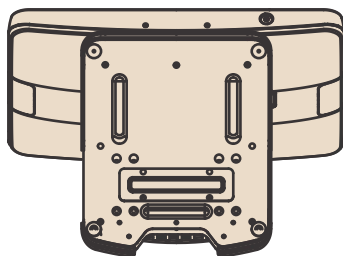
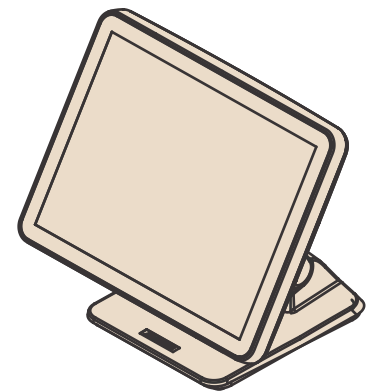
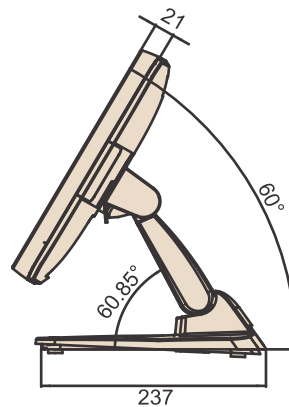
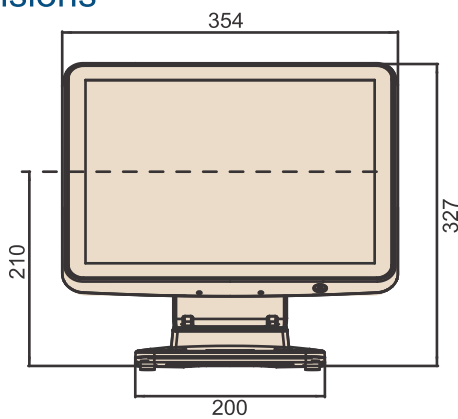

Interface Option

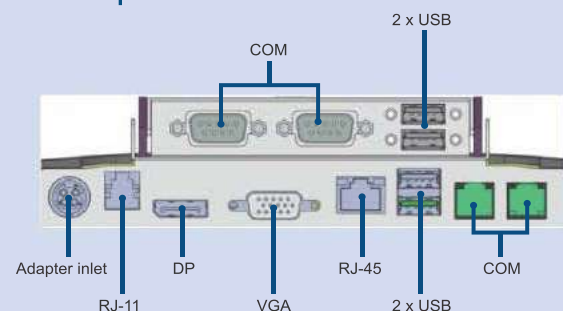

ADVANTECH-RAISER INDIA PRIVATE LIMITED,

H/O: #2nd floor -A-wing, Citi Centre survey No.79/2 Hennur Bellary Outer Ring Road,
Hebbal Village, Kasaba Hobli, Bangalore North Taluk, Bangalore-560024.

C/O: Unit No. 8, 1st Floor, Balwa Techniplex II, Off SV Rd, Goregaon West - 400062, Mumbai, India.

Contact Us: 9223434155